

Ausfräsung in der Oberseite / cut out in the top part

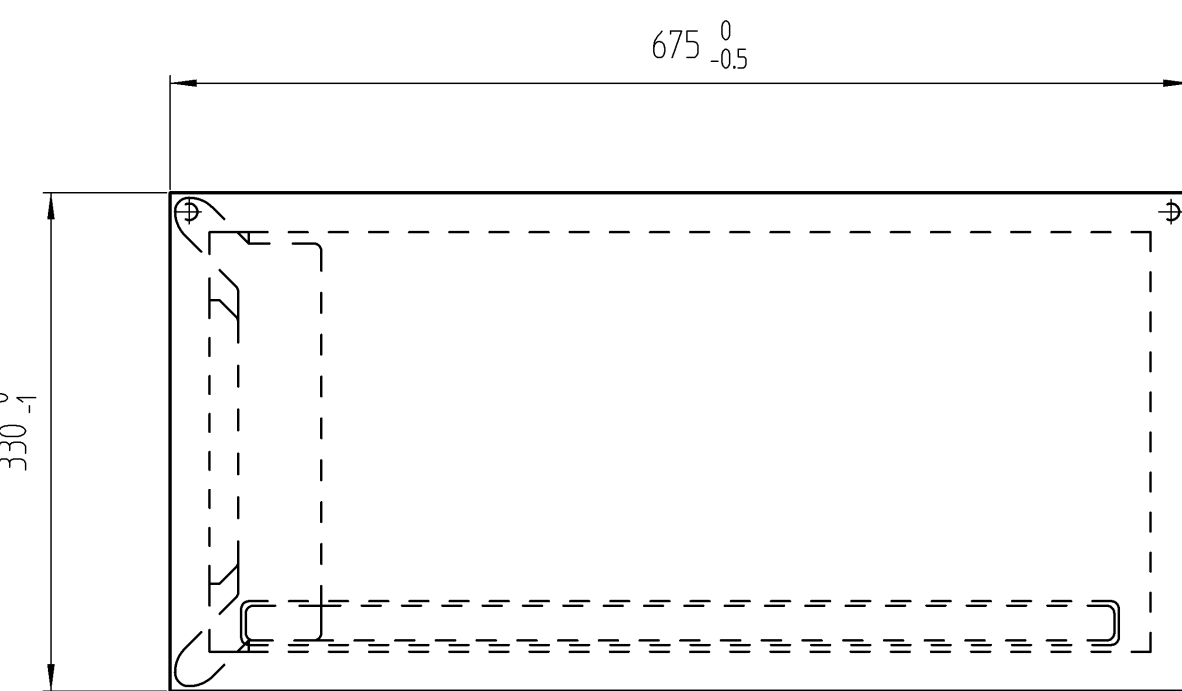

2mm sind einzuhalten, unabhängig von der Dicke der Platte  
2mm must be adhered to, regardless of the thickness of the panel

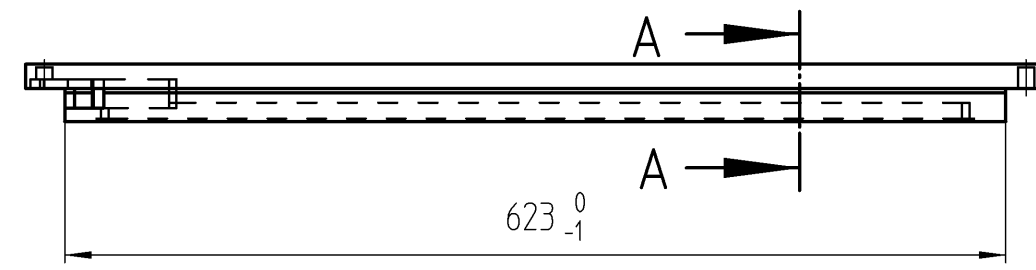
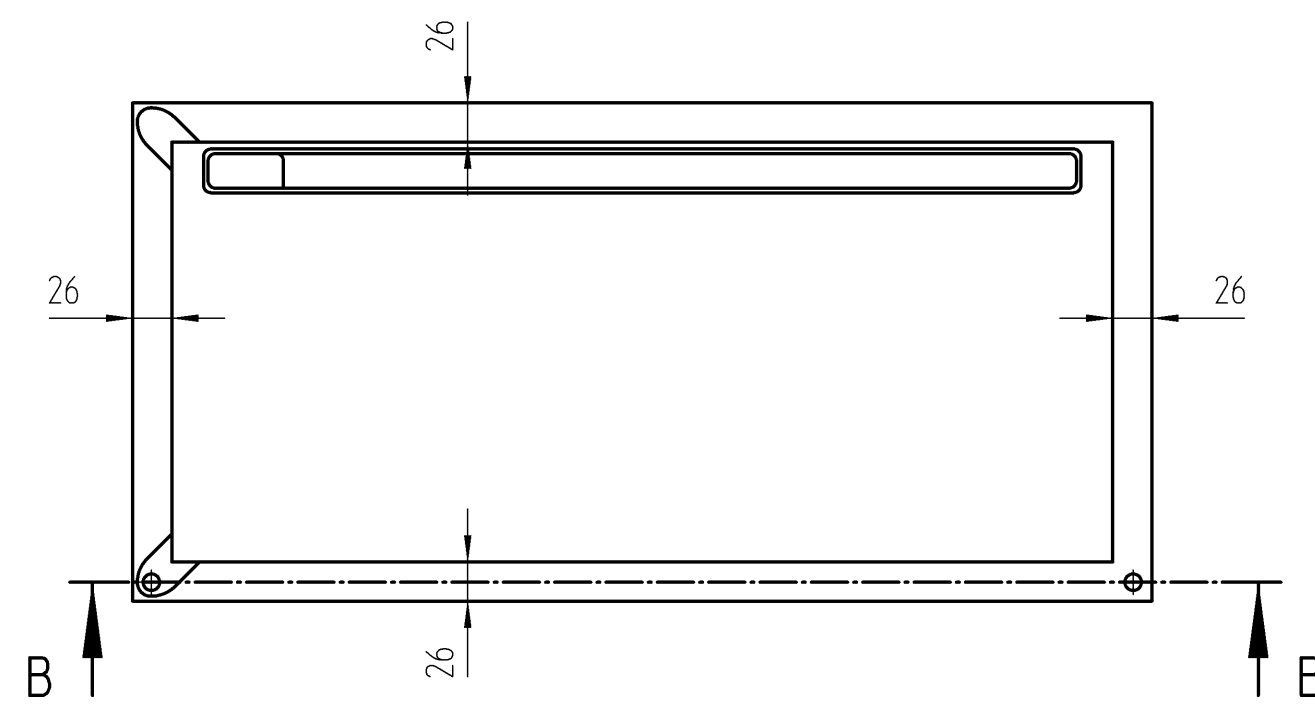
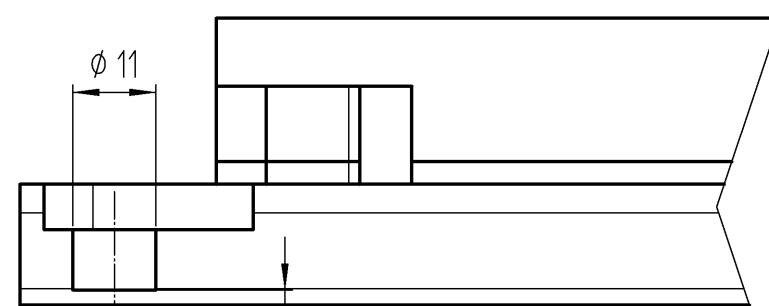

B-B 1:1

Plattmaße alle incl. Kanten  
panel dimensions incl. edges

ringsum mit Kanten belegt  
edged all around

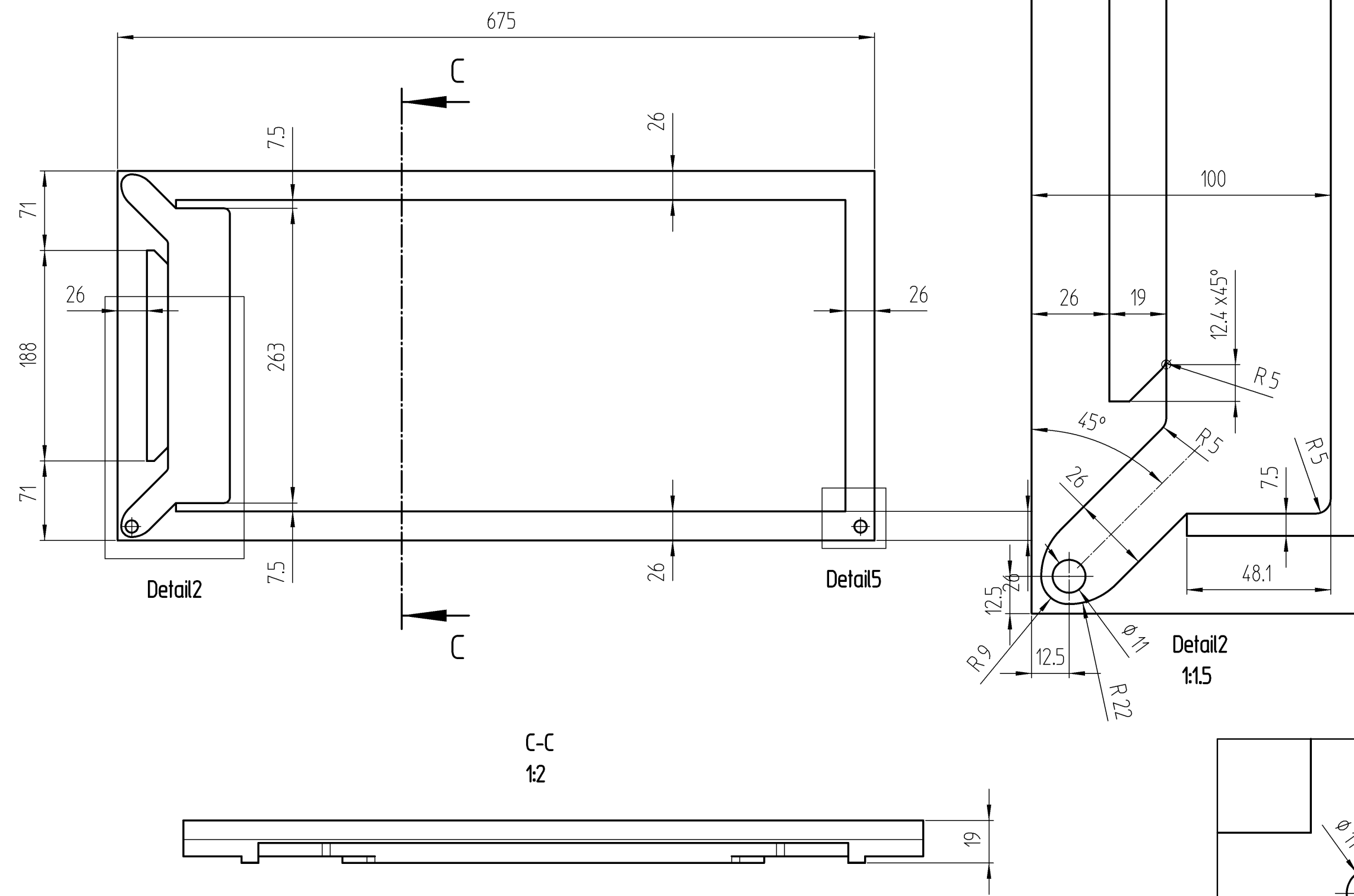
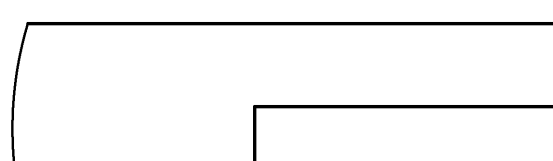

Ausfräsung in der Unterseite / cut out in the bottom part

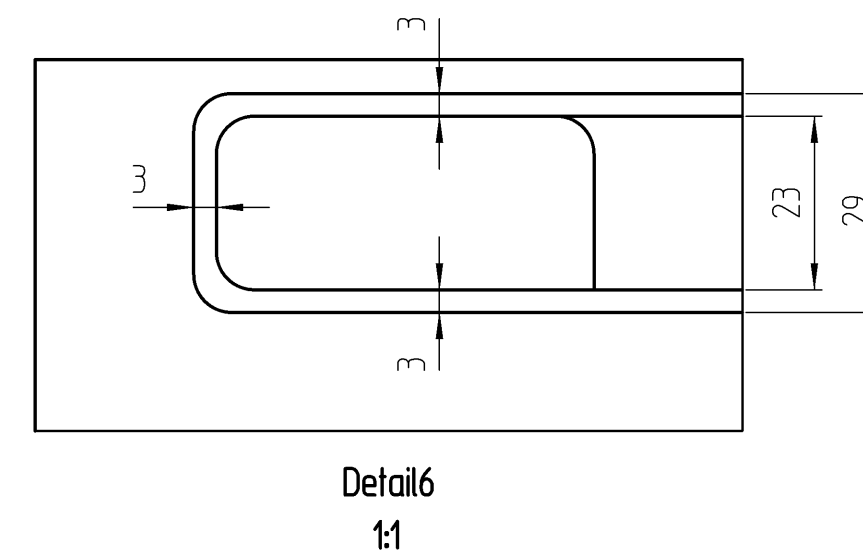
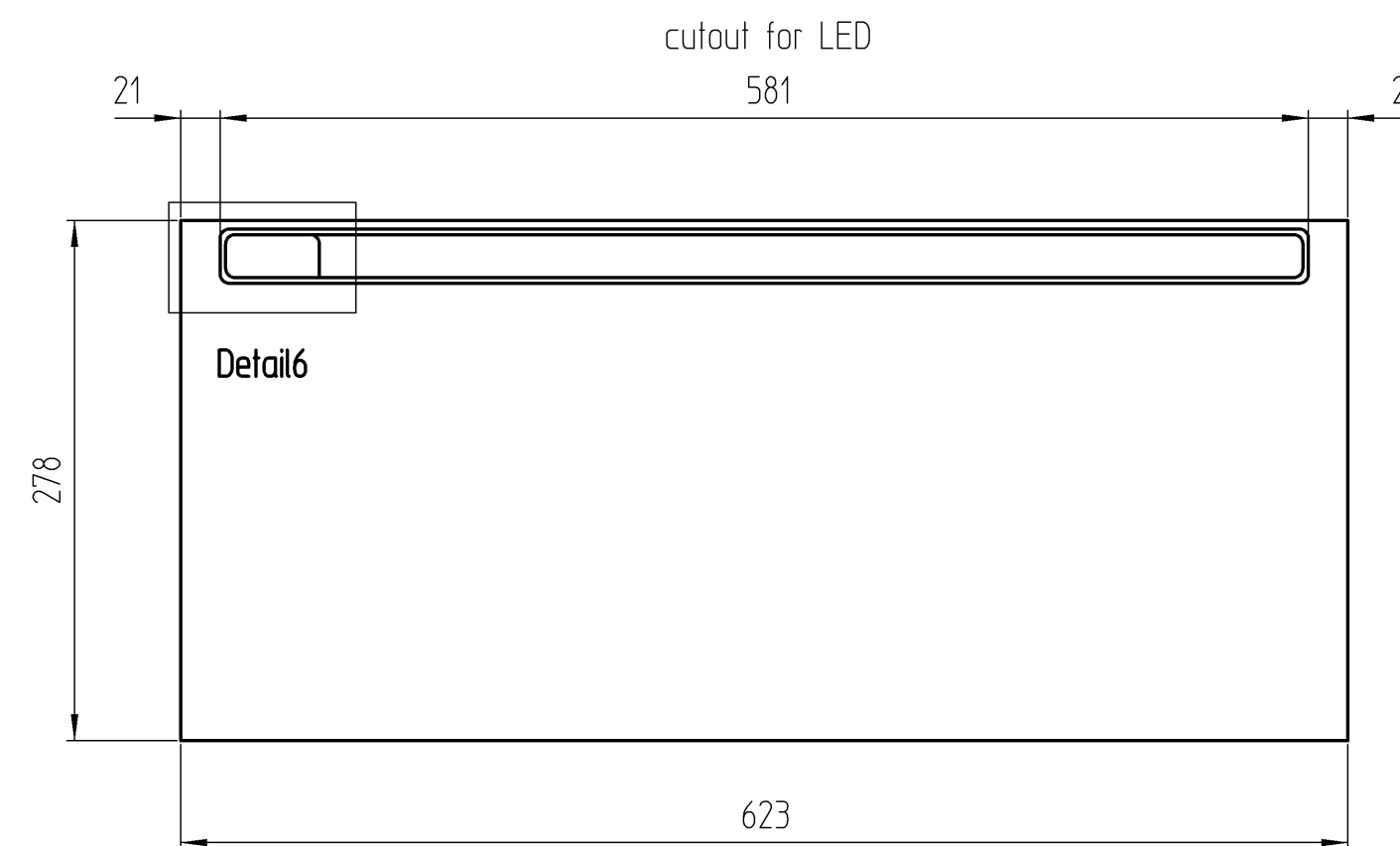

A-A 1:2

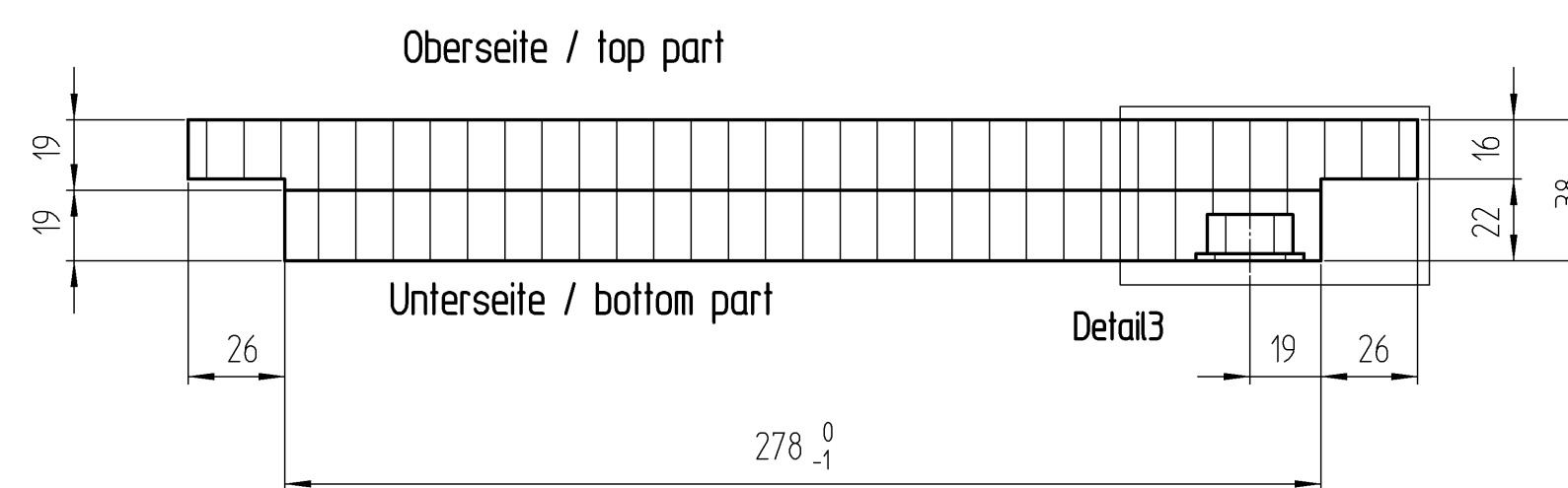

D-D 1:2

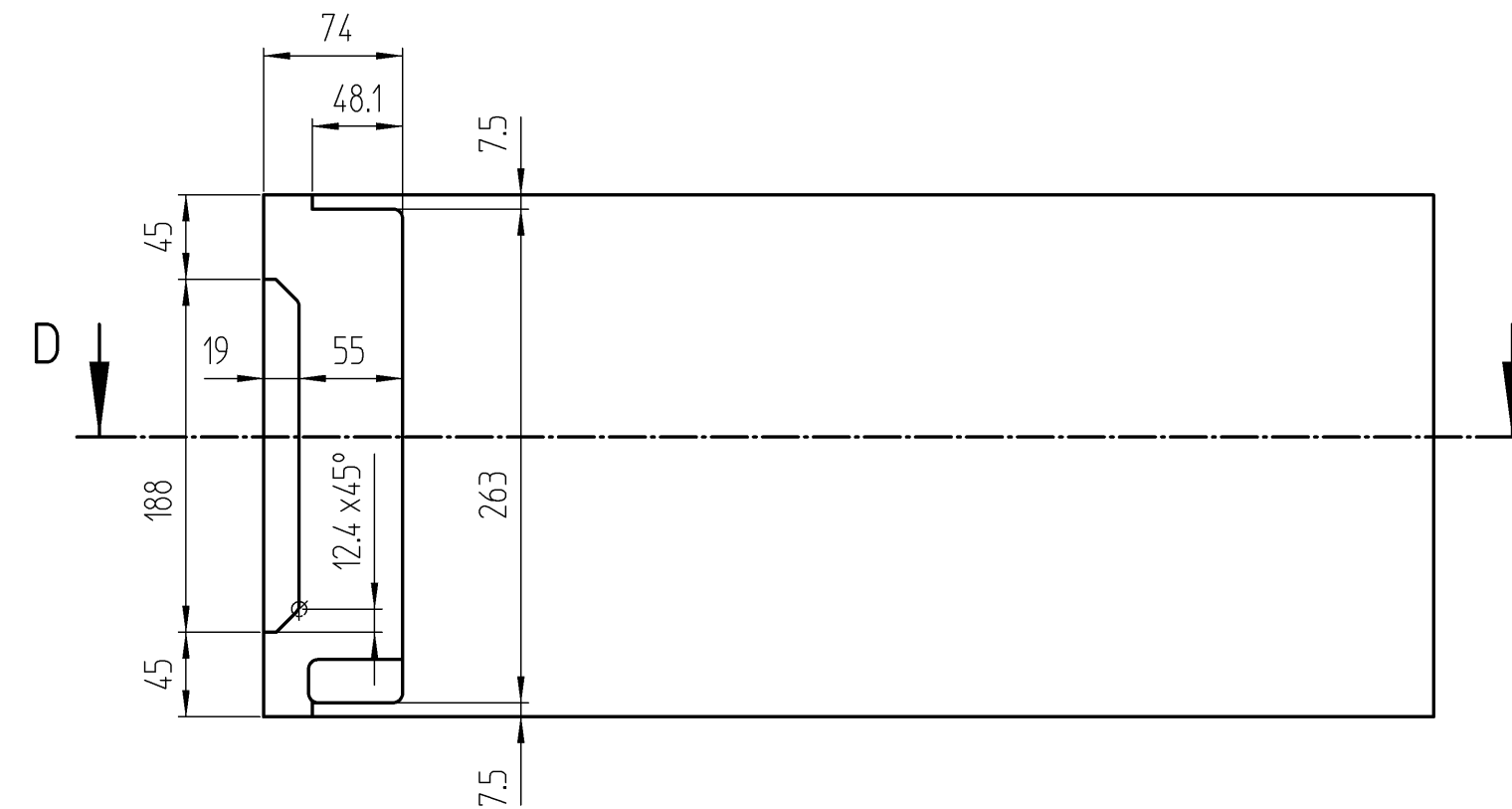

- Zweischaliger Deckel-Aufbau, mit einseitiger Leuchte / two-part top-construction, with one-sided light.
- Verklebt oder zb. geschraubt im Leuchtenkanal / glued or for example screwed in the light channel.
- Verkabelung und Stecker finden in der Ausfräsung platz / cabling and plugs are in the cut out.

- Deckel kpl. zusammen verleimt / both parts complete glued.
- Elektrifizierung nachträglich möglich / electrification later possible.

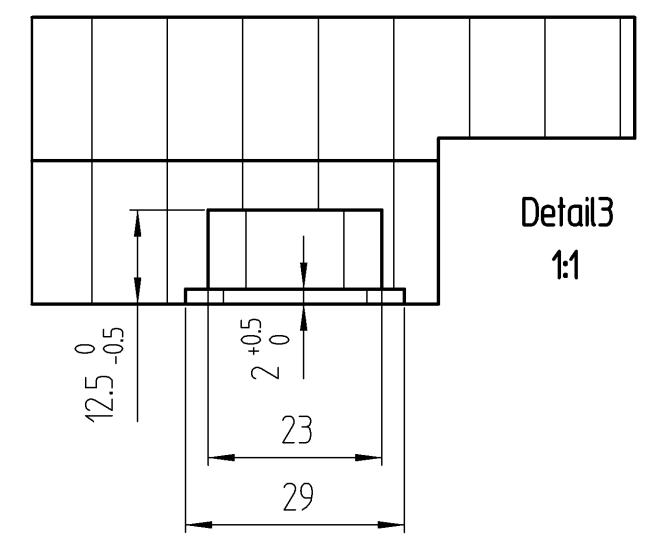
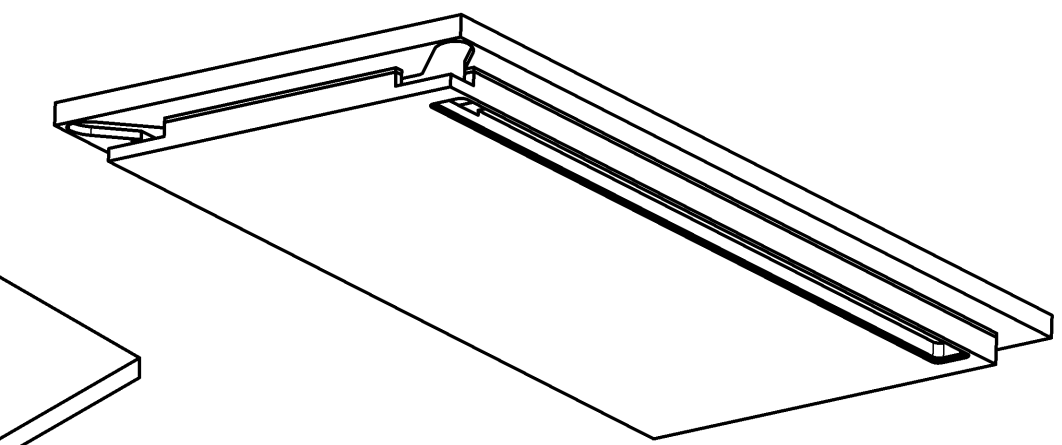
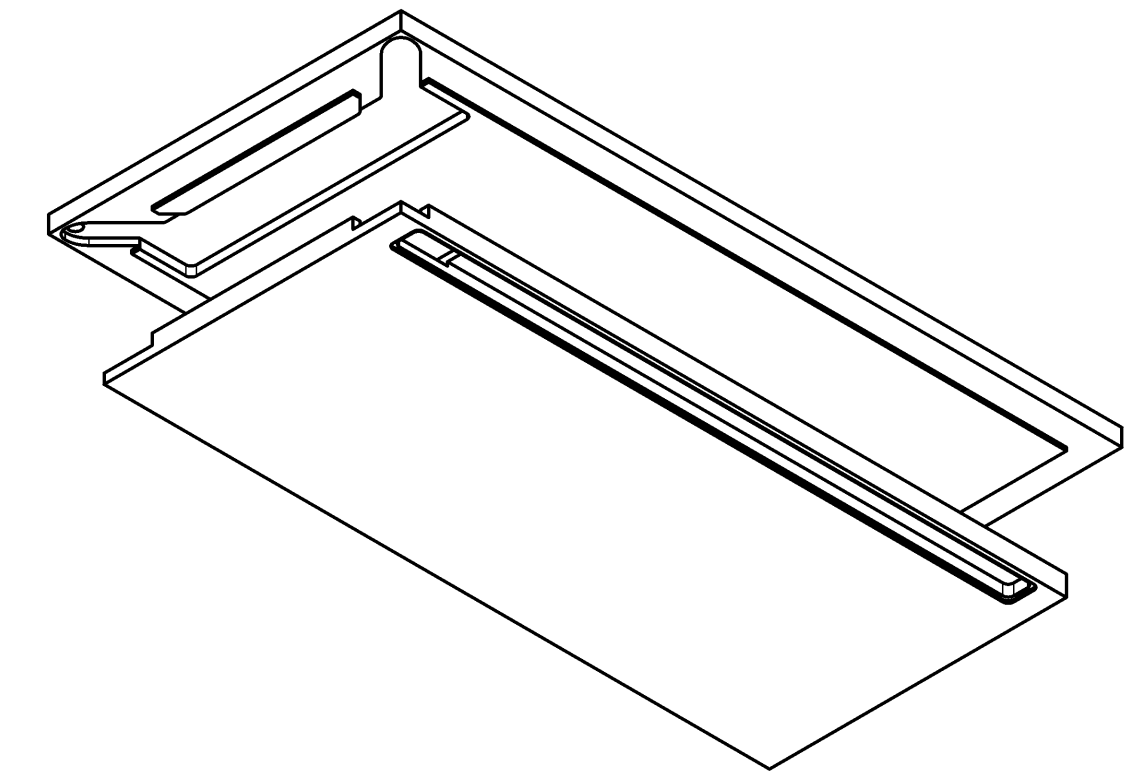
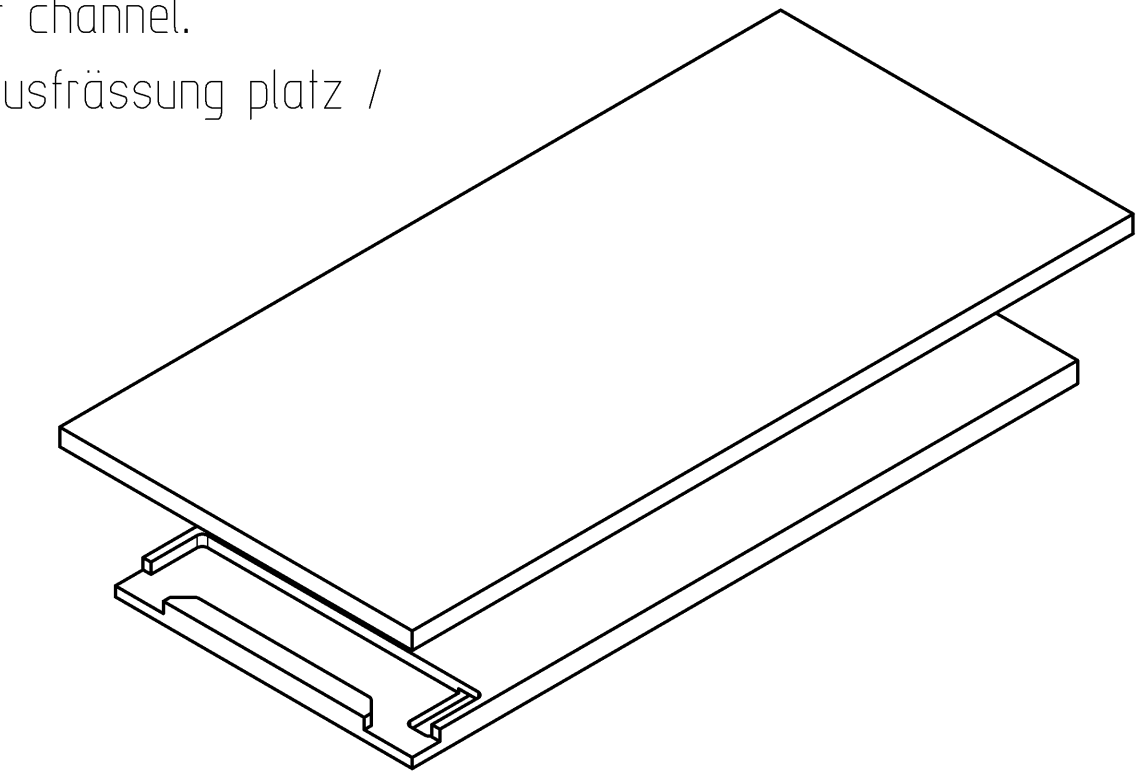

Detail3 1:1

Holz, Kanten und Oberfläche nach Auftrag  
Definierte Schmalseiten mit Kante belegt.  
Belegte Kante mit min. Radius R2mm versehen

wood, edges & surface to be advised  
defined narrow side covered with edges  
edges with R2mm

Piece	Designation/Description	Drawing/Mat.-Nr.	Pos	Material	DIN/VBN	Remark
Changings						
Used by	Date	Name	First used for	Weight/kg	5,166	Foreign designation
Designed	10.11.20	Studer_A	Free Dim. Tol.	Main Scale		Development No.
Released	16.11.20	Studer_A	HT 25	1:5		704-962 1 A 1/1
In Change						Replacement for
Designation				wooden shelf A650 T330 1xLED		
Project				Abdeckplatte A650 T330 1xLED		
Customer				901		
www.visplay.com						



Any intellectual property right subsisting in this drawing is owned by our company. Transferring, using or copying without permission is prohibited. Ohne unsere Genehmigung darf diese Zeichnung weder kopiert noch an Dritte Personen weitergegeben werden.